

## GATE - INSTRUMENTATION ENGINEERING SAMPLE THEORY

- **TRANSFER FUNCTION**
- **X-RAYS**
- **LASER**

# VPM CLASSES

For IIT-JAM, JNU, GATE, NET, NIMCET and Other Entrance Exams

1-C-8, Sheela Chowdhary Road, Talwandi, Kota (Raj.) Tel No. 0744-2429714

Web Site [www.vpmclasses.com](http://www.vpmclasses.com) E-mail-[vpmclasses@yahoo.com](mailto:vpmclasses@yahoo.com)

Toll Free: **1800-2000-092**

Mobile: **9001297111, 9829619614, 9001894073, 9829567114**

Website: [www.vpmclasses.com](http://www.vpmclasses.com)

FREE Online Student Portal: [examprep.vpmclasses.com](http://examprep.vpmclasses.com)

E-Mail: [vpmclasses@yahoo.com](mailto:vpmclasses@yahoo.com) / [info@vpmclasses.com](mailto:info@vpmclasses.com)

## 1. TRANSFER FUNCTION

- The input known as excitation or cause (denoted as  $r$ ) for any control system which operates through a transfer operation is termed as transfer function (denoted as  $g$ ).
- Transfer function produces an effect resulting in output or response termed as controlled variable (denoted as  $c$ ). Thus the cause and effect relationship between the output and input is related to each other through a transfer function.
- The relationship between the output and input is represented by a diagram known as block diagram as shown in Fig.

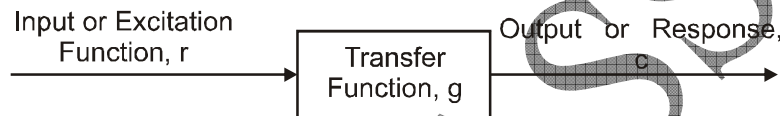

**Fig.1 Block diagram.**

- The arrow in the diagram indicates the direction of control action thus the block diagram has a unilateral property in the direction of arrow.
- The transfer function is expressed as the ratio of output quantity to input quantity. Therefore,

$$g = \frac{c}{r} \quad \dots(1)$$

As the cause and effect approach to control systems in general, it is not necessary that the output be of the same category as that of input. For example in the case of an electric motor the input is an electrical quantity, output being a mechanical one.

- With reference to control system where in all mathematical functions are expressed by their corresponding Laplace transforms, the transfer function is also expressed as a ratio of Laplace transform of output to Laplace transform of input.

Thus if,

$R(s)$  = Laplace transform of the input function

$C(s)$  = Laplace transform of the output function

then the block diagram for a control system is drawn as per Fig.1

The transfer function is expressed as,

$$G(s) = \frac{C(s)}{R(s)} \quad \dots(2)$$

While taking Laplace transformation for determining the transfer function of a control system, it is assumed that all the initial conditions concerning the differential equation are zero.

Hence the transfer function is,

$$G(s) = \frac{Lc(t)}{L\tau(t)} \quad \dots(3)$$

“The transfer function of a control system is defined as the ratio of the Laplace transform of the output variable to the Laplace transform of the input variable assuming all initial conditions as zero”.

- **Poles and Zeros of a Transfer Function**

The transfer function of a linear control system can be expressed in the form of a quotient of polynomials in the following form :

$$G(s) = \frac{A(s)}{B(s)} = \frac{a_0 s^n + a_1 s^{n-1} + a_2 s^{n-2} + \dots + a_n}{b_0 s^m + b_1 s^{m-1} + b_2 s^{m-2} + \dots + b_m} \quad \dots(4)$$

The numerator and the denominator can be factored into n and m terms respectively. With such a factorization the above expression for the transfer function can be expressed as,

$$G(s) = \frac{A(s)}{B(s)} = \frac{K(s-s_1)(s-s_2)\dots(s-s_n)}{(s-s_a)(s-s_b)\dots(s-s_m)} \quad \dots(5)$$

where  $K = \frac{a_0}{b_0}$  is known as the gain factor of the transfer function.

In the transfer function expression (5), if the numerator is equated to zero, then  $n$  roots of the equation are  $s_1, s_2, s_3, \dots, s_n$  where as equating the denominator to zero, the  $m$  roots can be determined as  $s_a, s_b, s_c, \dots, s_m$ .

- **Poles of the transfer function :** In the transfer function expression (5), if  $s$  is put equal to  $s_a, s_b, \dots, s_m$  it is noted that the value of the transfer function is infinite, hence  $s_a, s_b, \dots, s_m$  are called the Poles of the transfer function.
- **Zeros of the transfer function :** In the transfer function expression, if  $s$  is put equal to  $s_1, s_2, \dots, s_n$  it is noted that the value of the transfer function is zero, hence  $s_1, s_2, \dots, s_n$  are called the Zeros of the transfer function.
- The poles  $s_a, s_b, \dots, s_m$  or the zeros  $s_1, s_2, \dots, s_n$  are either real or complex and the complex poles or zero always appear in conjugate pairs.
- It is possible that either poles or zeros may coincide. Such poles or zeros are called multiple poles or multiple zeros, otherwise non-coinciding poles or zeros are called simple poles or simple zeros.
- The multiple poles/zeros occur due to the presence of repetitive factor in the denominator/numerator of a transfer function expression.
- The graphical symbol for a pole is  $X$  and for a zero  $O$ . The said symbols are used when poles and zeros are to be shown on real and imaginary axes ( $s$ -plane).
- The poles and zeros mentioned above are the finite ones. From equation (5) it is observed that:
  1. If  $n > m$ , then the value of the transfer function is found to be infinity for  $s = \infty$ . Hence, it is concluded that there exists a pole of the transfer function at infinity ( $s = \infty$ ) and the multiplicity (order) of such a pole being  $(n - m)$ .

2. If  $n < m$ , then the value of the transfer function is found to be zero for  $s = \infty$ . Hence it is concluded that there exists a zero of the transfer function at infinity ( $s = \infty$ ) and the multiplicity (order) of such a zero is  $(m - n)$ .

Therefore, in addition to finite poles and zeros of a transfer function, if poles and zeros located at zero and infinity are considered, then for a rational function the total number of zeros is found to be equal to total number of poles.

For example, consider the following transfer function:

$$G(s) = \frac{(s+2)(s+4)}{s(s+3)(s+5)(s+2-j4)(s+2+j4)}$$

For the above transfer function, the poles are at (1)  $s_a = 0$ , (2)  $s_b = -3$ , (3)  $s_c = (-2 + j4)$ , (4)  $s_d = (-2 - j4)$  and (5)  $s_e = -5$ . The zeros are at (1)  $s_1 = -2$ , (2)  $s_2 = -4$ .

As the number of zeros should be equal to number of poles, the remaining three zeros are located at  $s = \infty$ .

The pole-zero locations are plotted in  $s$ -plane as shown in Fig.

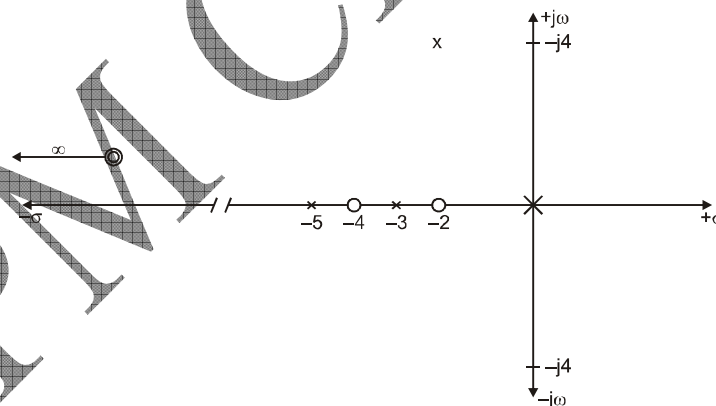

**Fig.2 Poles-zeros in s-plane.**

In the transfer function expression of a control system the highest power of  $s$  in the numerator  $A(s)$  is either equal to or less than that of the denominator  $B(s)$ . The transfer

function of a system is completely specified in terms of its poles and zeros and the gain factor.

- **Transfer Function and its Relationship with Impulse Response**

In a control system the output is related to the input by a transfer function as defined earlier, i.e.

$$\frac{C(s)}{R(s)} = G(s)$$

or 
$$C(s) = R(s) G(s) \quad \dots(6)$$

The output time response can be determined by taking inverse Laplace transform of relation (6). If the input is specified as unit impulse at  $t = 0$ , then  $R(s) = 1$  and the transformed expression for the system output, is,

$$C(s) = 1 \cdot G(s)$$

or 
$$C(s) = G(s) \quad \dots(7)$$

Thus the output time response is,

$$L^{-1} C(s) = L^{-1} G(s)$$

or 
$$c(t) = g(t) \quad \dots(8)$$

The inverse Laplace transform of  $G(s)$  is, therefore, called the impulse response of a system, or the transfer function of a system is the Laplace transform of its impulse response. The output impulse response of a system in time domain is thus solely determined by its transfer function. The transfer function of a system depends on its elements, assuming initial conditions as zero and it is independent of the input function.

- **Procedure for determining the transfer function of a control system**

The following steps give a procedure for determining the transfer function of a control system:

1. Formulate the equations for the system.



2. Take the Laplace transform of the system equations, assuming initial conditions as zero.
3. Specify the system output and the input.
4. Take the ratio of the Laplace transform of the output and the Laplace transform of the input.  
The ratio as obtained in step (4) is the required transfer function.

**Ex.1** The pole-zero configuration of a transfer function is given below (Fig.)

The value of the transfer function at  $s = 1$  is found to be 3.2. Determine the transfer function and gain factor  $K$ .

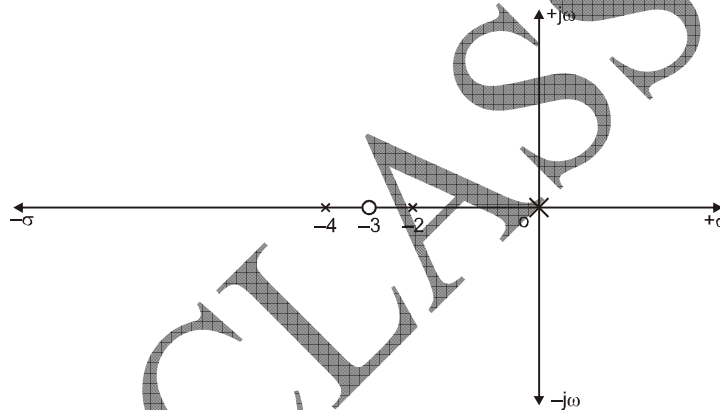

**Fig. Pole-zero configuration for example.**

**Sol.** The transfer function has three poles and one zero, therefore, the transfer function consists of one term in the numerator and three terms in the denominator.

The poles are located at  $s = 0$ ,  $s = -2$  and  $s = -4$

The zero is located at  $s = -3$

The transfer function is thus

$$G(s) = \frac{K(s+3)}{s(s+2)(s+4)}$$

It is given that at  $s = 1$ , the value of  $G(s)$  is 3.2

$$\therefore G(1) = 3.2 \frac{K(1+3)}{1(1+2)(1+4)} = \frac{K \times 4}{1 \times 3 \times 5}$$

$$\therefore K = \frac{3.2 \times 1 \times 3 \times 5}{4} = 12$$

$$\therefore G(s) = \frac{12(s+3)}{s(s+2)(s+4)}$$

## 2. X-RAYS

- X-rays are electromagnetic waves whose wavelength is more than that of  $\gamma$ -rays but less than that of ultraviolet rays, i.e. these rays lie in between the ultraviolet region and  $\gamma$ -rays region of electromagnetic spectrum.
- X-rays are emitted in the form of photons.
- Their wavelength is of the order of  $1\text{\AA}$  whereas their wavelength range is from  $0.1\text{\AA}$  to  $100\text{\AA}$ .
- **X-rays are of two types**  
(i) Soft X-rays      (ii) Hard X-rays
- **Difference between two types of X-rays**

Table 1

	Hard X-rays	Soft X-rays
1.	Their penetrating power is high.	Their penetrating power is low.
2.	Their wavelength is less ( $0.1\text{\AA} - 10\text{\AA}$ ).	Their wavelength is more ( $10\text{\AA} - 100\text{\AA}$ ).
3.	Their frequency is high ( $10^{18}$ Hz)	Their frequency is low ( $10^{16}$ Hz)
4.	Their energy is high ( $10^4$ eV)	Their energy is low ( $10^2$ eV)

- X-rays were discovered by Roentgen, hence these are also known as Roentgen rays.

### Properties of X-rays

Toll Free: [1800-2000-092](tel:1800-2000-092)      Mobile: [9001297111](tel:9001297111), [9829619614](tel:9829619614), [9001894073](tel:9001894073), [9829567114](tel:9829567114)

Website: [www.vpmclasses.com](http://www.vpmclasses.com)      FREE Online Student Portal: [examprep.vpmclasses.com](http://examprep.vpmclasses.com)

E-Mail: [vpmclasses@yahoo.com](mailto:vpmclasses@yahoo.com) / [info@vpmclasses.com](mailto:info@vpmclasses.com)



- X-rays are uncharged, invisible electromagnetic waves which are emitted in the form of photons.
- Their velocity is equal to that of light (i.e.  $3 \times 10^8$  m/s)
- These are not affected by electric and magnetic fields.
- They obey all the laws of light and exhibit the phenomena like reflection, refraction, diffraction, interference and polarization etc.
- After traversing x distance through matter their intensity reduces to

$$I = I_0 e^{-\mu x}$$

- For X-ray photography of human body parts,  $\text{BaSO}_4$  is the best absorber.
- X-rays are diffracted by crystals according to Bragg's law.

### X-ray spectra and related features

#### (A) Continuous X-ray spectrum Production

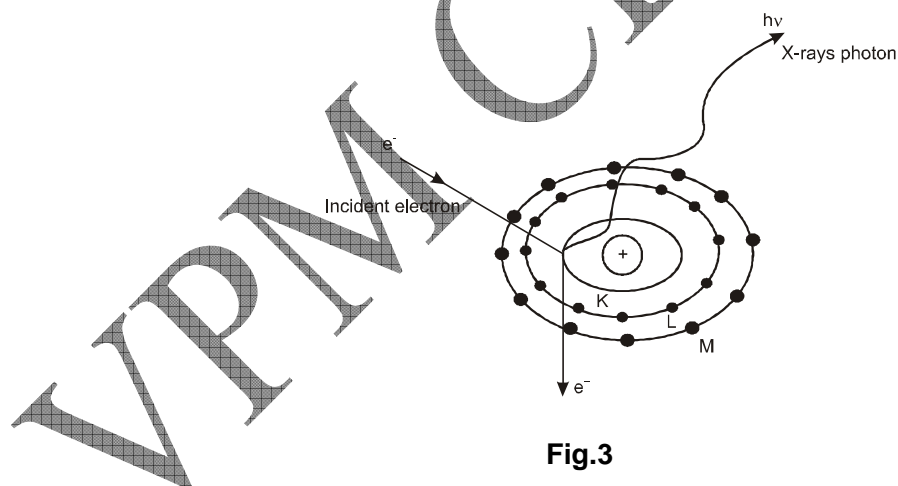

Fig.3

- When high energy electrons pass close to the nucleus of target atom then these get decelerated due to Coulomb attractive force of nucleus, then X-rays of continuous frequency and energy are emitted.

- Accelerated or decelerated charges emit electromagnetic radiations which are known as *Bremsstrahlung radiations*.
- The minimum wavelength of continuous X-rays depends on the applied potential difference

$$(i) \lambda_{min} = \frac{hc}{eV} = \frac{12400}{V} \text{ \AA}$$

## (B) Characteristic X-ray spectrum

### Production

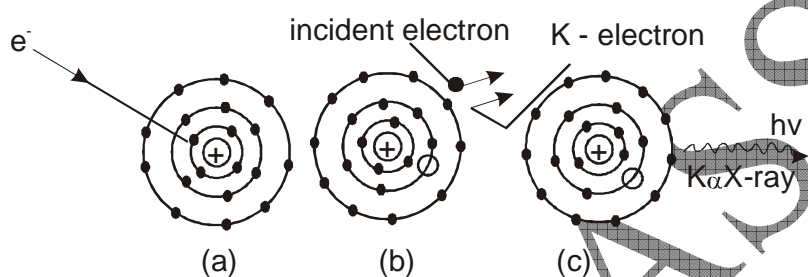

Fig.4

When high energy electrons penetrate target atoms, they strike the electrons of inner shells and knock them out from the atoms, then deficiency of electron is created in the inner shell. To fulfill this deficiency, electron from some higher shell jumps into this shell as a result of which characteristic X-rays are emitted. In this process photons of energy equal to the difference of energies of initial and final shells are emitted.

- The energy spectrum of these X-rays is a line spectrum in which series of various frequencies or wavelengths are obtained.

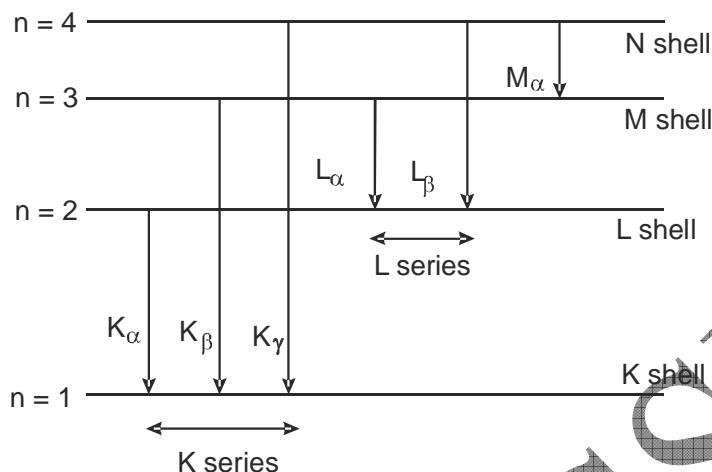

Fig.5

- (i) **K-series**:- When electron makes transitions from  $n = 2, 3, 4..$  to  $n = 1$  state, then K-series of X-rays is emitted.
- (ii) **L-series**:-When electron makes transitions from  $n = 3, 4, 5..$  to  $n = 2$  state, then L-series is emitted.

### Mosley's law

- (a) The frequency of characteristic X-ray spectral line is directly proportional to the square of atomic number of target element i.e.

$$\nu \propto Z^2 \text{ or } \sqrt{\nu} \propto Z$$

$$\sqrt{\nu} = a(Z - \sigma) \quad \text{For } K_{\infty} \text{ line } \sigma_k = 1$$

### Diffraction of X-rays

- The diffraction of X-rays is possible by the crystals and not by ordinary grating, because the inter-atomic spacing in a crystal lattice is of the order of wavelength of X-rays whereas the size of grating element is much larger than the wavelength of X-rays.

$$2d \sin \theta = n\lambda$$

The reverse phenomenon of X-rays is known as photoelectric effect.

### 3. LASERS

- Laser is a powerful source of light having extraordinary properties. The unique property of laser is that its light waves travel very long distances with very little divergence.
- In case of a conventional source of light, the light is emitted in a jumble of separate waves that cancel each other at random (Fig. 6a) and hence can travel very short distances only.
- In laser, the light waves are exactly in step with each other and thus have a fixed phase relationship (Fig. 6b).
- This coherency makes the laser light very narrow, powerful and easy to focus on a given object.

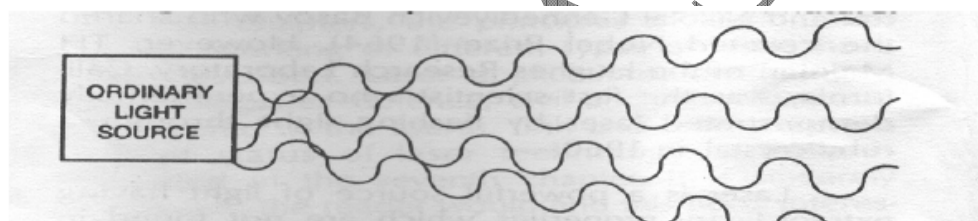

Fig.6(a)

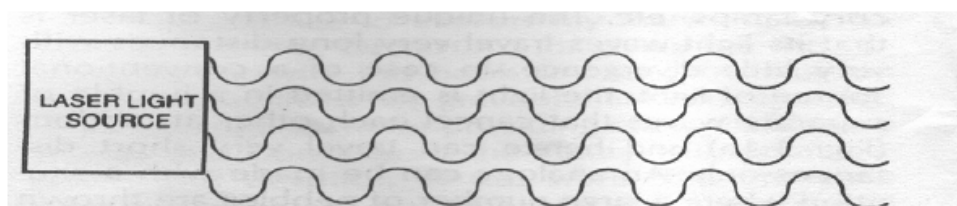

Fig.6(b)

- Principle of Laser Action

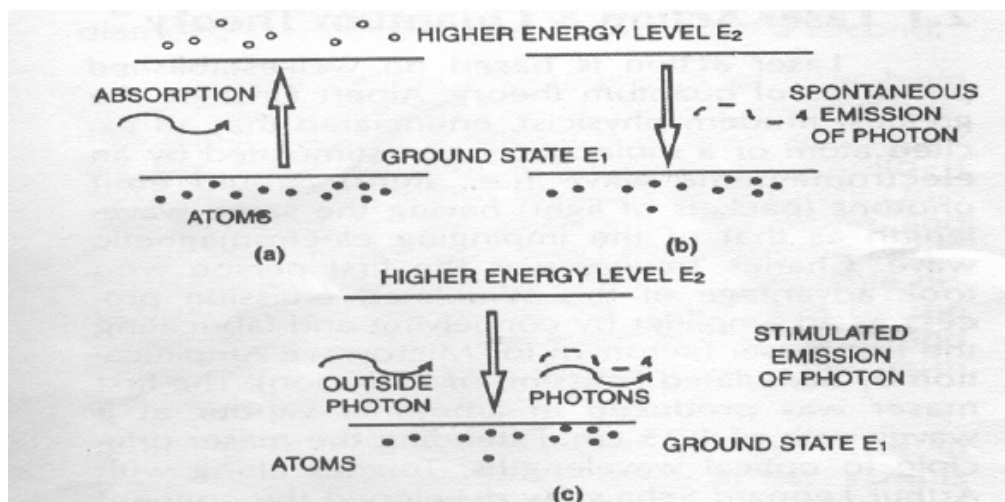

Fig.6(c)

Every atom, according to the quantum theory, can have energies only in certain discrete states or energy levels. Normally, the atoms are in the lowest energy state or ground state.

When light from a powerful source like a flash lamp or a mercury arc falls on a substance, the atoms in the ground state can be excited to go to one of the higher levels. This process is called **absorption**. After staying in that level for a very short duration (of the order of  $10^{-8}$  second), the atom returns to its initial ground state, emitting a photon in the process. This process is called spontaneous emission.

The two processes, namely, absorption and spontaneous emission, take place in a conventional light source,

In case the atom, still in its excited state, is struck by an outside photon having precisely the energy necessary for spontaneous emission, the outside photon is augmented by the one given up by the excited atom. Moreover, both the photons are released from the same excited state in the same phase. This process, called **stimulated emission**, is fundamental for laser action (Fig.6c). Thus, the atom is stimulated or induced to give up its photon earlier than it would have done ordinarily under spontaneous emission.

- LASERS IN MEDICINE**

Clinical use of lasers.

Dermatology	Pulsed dye Ar, CO <sub>2</sub> , Nd : YAG, ruby
ENT	CO <sub>2</sub> , Nd : YAG
Ophthalmology	Ar, kV, Nd : YAG (Pulsed), Excimer, dye
Urology	Na: YAG, Sapphire
Plastic surgery	CO <sub>2</sub> ,
Stone fragmentation	Pulsed dye, pulsed Nd: YAG etc.

- (i) **In medicine:** The lasers are used primarily to deliver energy to tissues. The laser wavelength used should be strongly absorbed by tissues. The laser energy directed at human tissue causes a rapid rise in temperature and can destroy the tissues. The amount of damage to living tissue depends on how long the tissue is at the increased temperature.
- (ii) **In ophthalmology:** Lasers are primarily used for photo coagulation of the retina, i.e. heating a blood vessel to the point where the blood coagulates and blocks the vessel. The amount of laser energy needed for photo coagulation depends on the spot size used.
- A complication of diabetes that affects the retina called diabetic retinopathy is also treated with photo coagulation. Because of the small spot size available (~50  $\mu\text{m}$ ), it is possible to use the laser even in the small region where our detail vision takes place.
- (iii) **In neurosurgery:** Large tumors of brain stem and spinal chord are vaporized using CO<sub>2</sub>, argon and Nd : YAG lasers.
- (iv) **In urology:** Treatment of tumors of bladder and contractures or structures of urethra is done through YAG lasers. The fiber is inserted through a urethroscope.



- (v) **In orthopedics:** Argon laser is used for photocoagulation of bleeding vessels near spinal chord. Injuries to cartilages of the knee are repaired using arthroscopes and YAG lasers.
- (vi) **In dermatology-phastic surgery:** Laser is used in the treatment of Portwine strains (PWS), removing tattoos, and removing Telangiectasis (small red spots on skin).
- (vii) **In obstetrics-gynecology:** In traepithelial cancers vulva or skin of genitalia and premaliagnant and malignant conditions of Cervix and Vagina are treated by using CO<sub>2</sub> lasers coupled with a calposcope in which magnifying microscope are designed, so that pre-malignant area can be visualized and observed during coagulative vaporization procedure.

VPM CLASSES